

# 17 Practical Microwave Antennas



Andy Barter, G8ATD

The big advantage that microwave antennas have over those used for other amateur bands is that they are relatively small. We can let our imagination loose and have antennas with gains that are not achievable elsewhere and mount them at heights, in wavelengths, that users of the lower frequency bands can only dream of.

This chapter has been organised by type of antenna rather than by band usage, the types being:

- **Patch antennas:** These are easily constructed because they are etched onto printed circuit board. They are small and have found lots of applications in commercial electronics such as mobile phones, cordless phones and local area networks. If you need a small antenna, the patch may suit your needs.
- **Slot antennas:** These are omni directional and can be used for repeaters or mobile use.
- **Helical antennas:** The big advantage of the helical antenna is that it is circularly polarised. This has made it widely used for satellite operation.
- **Yagi antennas:** The Yagi is probably the best known antenna. With the reduced element size on the microwave bands some impressive gains can be achieved.
- **Horn antennas:** As the frequency increases, the horn antenna comes into its own at 10GHz and above.
- **Dish antennas:** Ideal for high gain antennas but more difficult to build. With the availability of offset dishes for the satellite TV market they are a good choice, but calculating where they are pointing is more difficult. Paul Wade has all the answers for using an offset dish. Amazingly, Michael Kohla, DL1YMK uses a dish for portable moonbounce DXpeditions, his design shows what can be achieved if you are really dedicated to amateur radio.

## PATCH ANTENNA

### Antenna for 5.8GHz

This design was produced by Gunthard Kraus, DG8GB as a practical project to design a patch antenna for 5.8GHz [1].

The techniques described here can be used to design patch antennas for any of the lower amateur microwave bands, ie 23cm to 3cm. The main design work uses PUFF CAD software, this will run on a wide range of PCs running DOS to Windows XP, the use of the software is described in much more detail in the reference material [1], [2].

The patch antenna was developed for the 5.8GHz ISM (Industrial, Scientific and Medical) band for monitoring video feeds two floors away in the new Tettmanger Electronic Museum in Germany. Since no holes could be bored and no slots could

```

These are the design parameters:

Length (L) = .5271 inches
Width (W) = .8 inches
Height (H) = .032 inches
Dielectric Constant (D) = 3.38
Loss Tangent (T) = .001
Feedpoint Distance (F) = 0 inches

Do you wish to edit any value? (Y/N):
    
```

Fig 17.2: The input parameters for Patch 16

be cut out for cables in the historic museum building, the designers simply used the wall of the house opposite as the reflector for the 5.8GHz signal; the patch antenna was aligned with it. The 5.8GHz ISM band contains 16 channels at 9MHz intervals. between 5732MHz and 5867MHz.

The antenna thus has to display a self-resonant frequency of 5800MHz and a bandwidth of approximately 140MHz (2.4%). The input resistance should be 50 ohms, with a semi-rigid cable having a soldered SMA plug. The circuit board is made from Rogers R04003, which is a very stable material from the mechanical point of view and is easy to machine. It should have the following specification:

- $\epsilon_r = 3.38$
- Printed circuit board thickness = 32mil (0.813mm)
- Dielectric loss factor = 0.001
- Copper coating = 35 $\mu$ m

A  $\lambda/4$  line transforms the antenna radiation resistance to the required 50 $\Omega$ . The circuit board size should be 50mm x 50mm and a short 50 $\Omega$  microstrip is needed from the transformation line to the cable connection on the circuit board. This can be seen clearly in the photograph of the finished product in Fig 17.1.

### Design Procedure

The basic procedure can be found in an article on the subject from *VHF Communications* [2], [3].

After a little experimenting with the *patch16* program (available from the Internet [4]), an initial design was produced with a

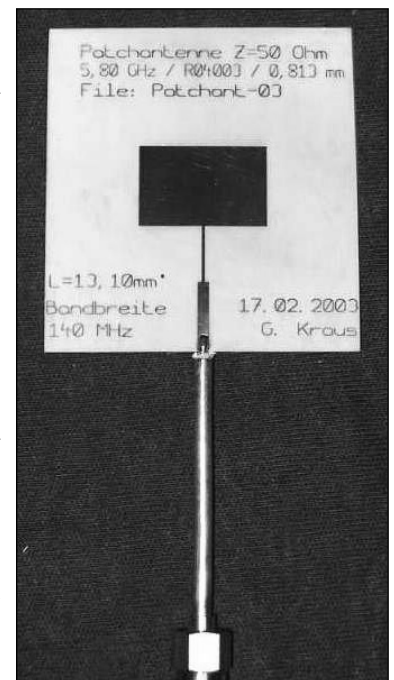

Fig 17.1: The finished patch antenna for 5.8GHz

```

The Resonant Frequency is 5.800 GHz
Qo is 26.0

The Edge Radiation Resistance is 142.42 ohms
Zc of Quarter-wave transformer is 84.4 ohms
Approx. width of the Quarter-wave transformer is 0.028 inches
Length of Quarter-wave transformer is 0.321 inches at the Resonant Freq.

Input Resistance at probe location is 142.42 ohms

The 2:1 USWR Bandwidth is 2.9%
Upper Frequency Limit = 5.883 GHz
Lower Frequency Limit = 5.716 GHz

Press 'ENTER' to continue: █
    
```

Fig 17.3: Simulation results for the patch antenna

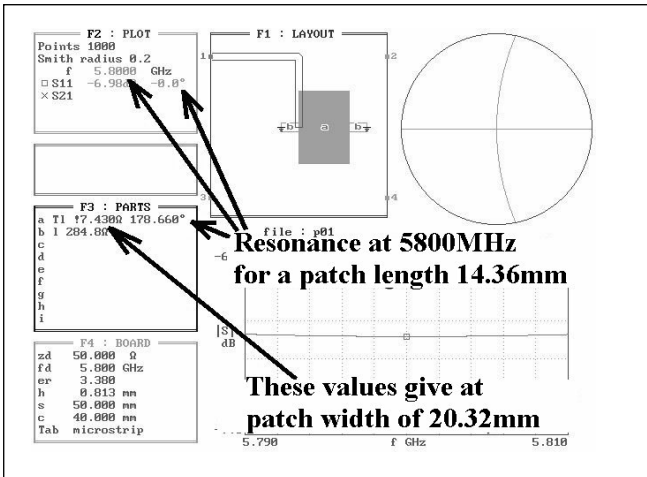

Fig 17.4: Simulation of the patch antenna using PUFF

centre frequency of exactly 5800MHz, while the bandwidth was deliberately increased to 2.9%.

The input and calculated characteristics of the antenna can be seen in Figs 17.2 and 17.3. The values required for the subsequent work using PUFF [5] must first be converted from inches into millimetres:

- Patch width = 20.32mm
- Patch length = 13.39mm
- Total radiation resistance = 142.4Ω, which gives 284.8Ω on each patch edge.

A text editor is needed to open the setup file of PUFF21, and to enter the R04003 material and circuit board data. PUFF is started up (work with the protected mode version by loading puffp.exe) and the patch is modelled as a large width, lossy transmission line. The two radiation resistances are positioned on the two patch edges and the centre frequency is set at 5.8GHz.

First, delete the exclamation mark after the entry "TL" in field F3, and experiment with the characteristic impedance of the line until (once the equals sign has been entered) a width of w = 20.32mm is set.

Now replace the exclamation mark, and vary the electrical length of the line until the configuration is as near as possible to resonance. This situation can easily be recognised, since then the phase angle of S11 is exactly zero degrees. Remember to select a swept frequency range as small as possible, and also try to obtain the highest possible resolution for the amplitude range for |S11|. The process is clarified in Fig 17.4, which immediately supplies the required data. For a patch width of 20.32mm, a microstrip line is needed with a characteristic impedance of 7.43Ω at low frequencies. A mechanical length of 14.36mm has an electrical length of λ/2 at 5.8GHz.

Note: If you're surprised by the big difference between this length value of 14.36mm and the patch16 suggestion of L = 13.39mm, the following will clear up the mystery. First the patch has to be shortened by the open-end extension on both sides. More on this subject later, but the result can be given in advance: it is 0.41mm on each side. But this only reduces the length to 14.36mm - 2 x 0.41mm = 13.53mm. The difference is provided by something discovered by chance in the specialist literature: "... the difference between the patch resonance and the electrical length for the corresponding λ/2 microstrip is about 1% ...". Thus 0.99 x 13.53mm = 13.40mm.

Using a λ/4 transformation line, the input resistance of the configuration must be brought to precisely 50Ω. In Fig 17.5, this has already happened, and the required data are:

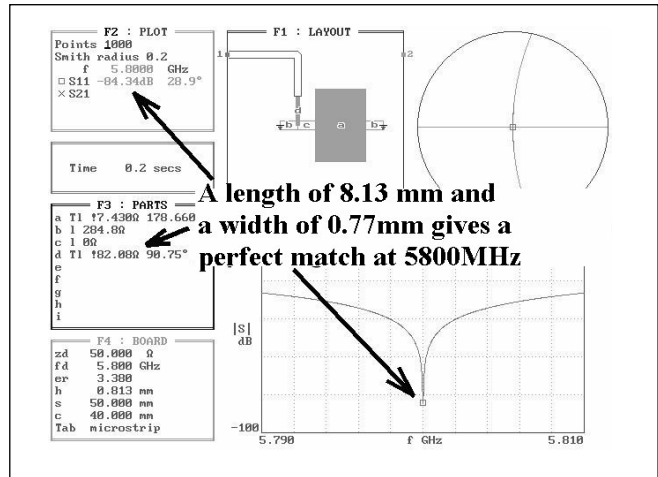

Fig 17.5: Using a quarter-wave transmission line, the input resistance is matched to 50Ω

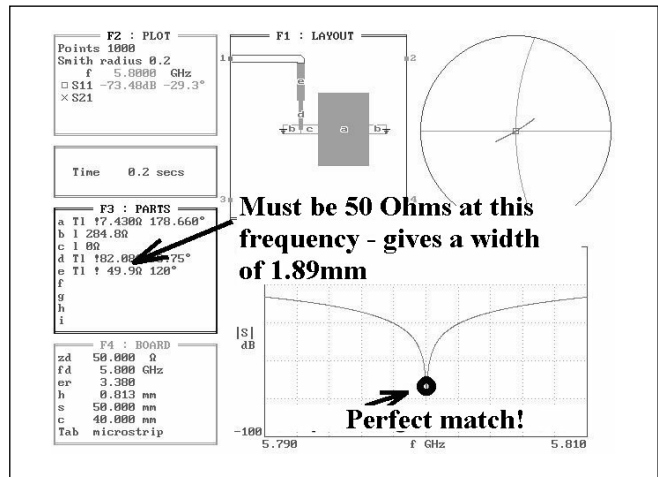

Fig 17.6: Matching patch antenna to 50Ω

- Line length = 8.18mm
- Line width = 0.765mm

Providing the configuration with a 50-ohm feed (required length about 11mm up to the edge of the board), is shown in Fig 17.6.

From this, the width of the feed can be determined (once again, after removing the exclamation mark after "TL" and pressing the equals sign) at w = 1.89mm. First, the open-end extensions for the microstrip line must be determined. The quickest way is still to use the appropriate diagram from the PUFF manual. Fig 17.7 shows the necessary procedure and also supplies the raw data required:

- For a patch with Z = 7.4Ω use 51% of the board thickness of 0.813mm = 0.42mm
- For the 50Ω feed, use 45% of the board thickness of 0.813mm = 0.37mm

Since the transformation line displays the highest characteristic impedance and thus the smallest width, it must be extended by the following amounts at both ends (the correction formulas can be found on the same page in the PUFF manual):

For the patch side, the result is:

$$\Delta L = \left(1 - \frac{w_2}{w_1}\right) \cdot 0.42 = \left(1 - \frac{0.77}{20.32}\right) \cdot 0.42 = 0.41\text{mm}$$

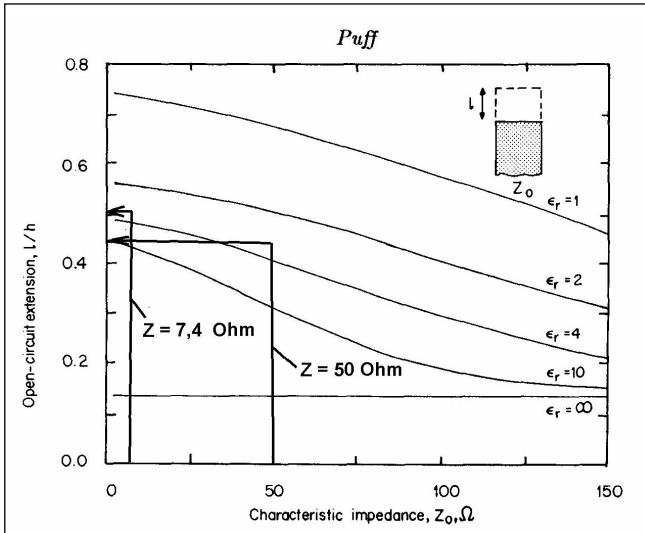

**Fig 17.7: Determining the open end extension using the graph published in the PUFF manual**

For the feed side, the result is:

$$\Delta L = \left(1 - \frac{w_2}{w_1}\right) \cdot 0.37 = \left(1 - \frac{0.77}{1.89}\right) \cdot 0.37 = 0.22\text{mm}$$

So for the transformation line, the requirements are a length of 8.18mm + 0.41mm + 0.22mm = 8.81mm, and a width of 0.77mm. The best way to work on the patch is to use the length supplied by the Patch16 program, ie 13.39mm, with a patch width of 20.32mm.

Using a printed circuit board CAD program, centre the patch on the selected circuit board (dimensions 50mm x 50mm), add the transformation line, and finally connect the feed line, with a width of 1.89mm, up to the board edge as in Fig 17.1.

Now the semi-rigid cable, with an SMA plug, must be connected to the circuit board with the minimum of electrical irregularities as shown in Fig 17.8: The method is as follows:

- First, saw off the cable and carefully file the end flat at an angle. Do not forget to trim it.
- Using a fine saw (eg a jig saw), make a cut parallel to the cable and a few millimetres long, precisely following the inner conductor.
- Carefully cut perpendicular to the cable to expose the inner conductor completely and remove the internal Teflon insulation.
- Push the circuit board into this cut solder the inner conductor to the 50Ω microstrip feed line. Carefully solder the remainder of the cable sheathing to the underside.

An investigation of the antenna using an HP8410 network analyser, HP5245L microwave counter and an HP5257 transfer oscillator, gave the resonance at 5690MHz, with a value of  $|S_{11}| = -16\text{dB}$ .

A more precise examination, using a polar display, showed that the input resistance here exceeds the system resistance of 50 ohms and consequently the radiation resistance must have a higher value. These findings were immediately converted into a PUFF simulation, and it became clear that in reality a resistance of 407.5 ohms should be assumed on each patch edge (Fig 17.9).

The patch length required for 5890MHz should be displayed immediately in the F3 parts list - it amounts to  $L = 14.65\text{mm}$ . Now, in the F4 field, simply change the design frequency to the required 5800MHz, thus once again simulating the patch resonance at this

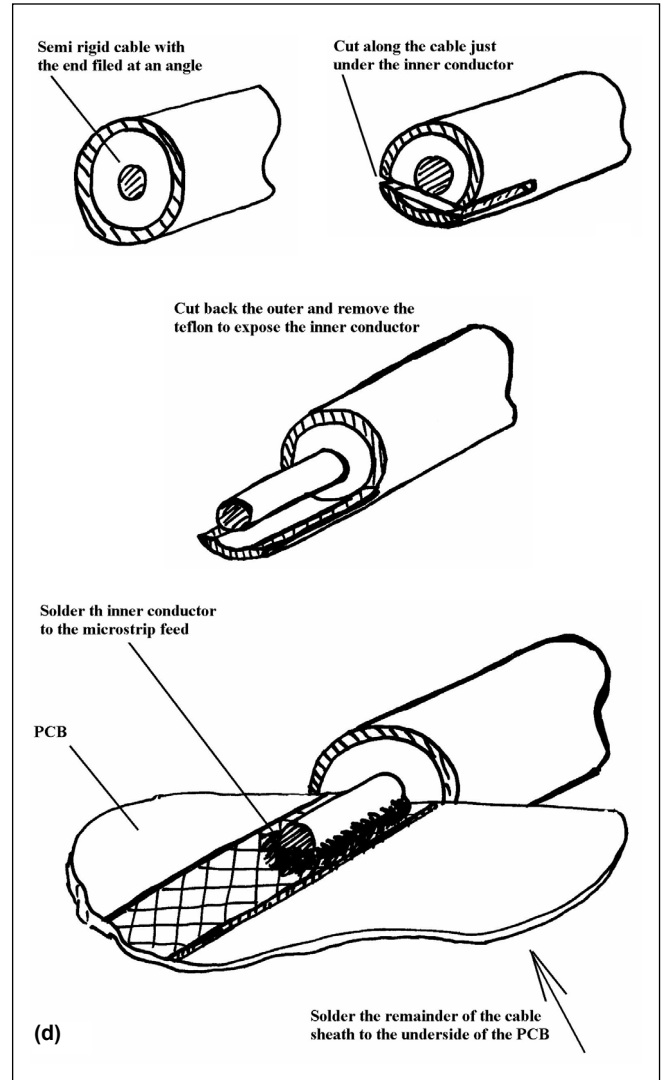

**Fig 17.8: Details of how to fit the semi-rigid feeder. (8a) Semi rigid cable with the end filed at an angle. (8b) Cut along the cable just under the inner conductor. (8c) Cut back the outer and remove the teflon to expose the inner conductor. (8d) Solder the inner conductor to the microstrip feed and the cable sheath to the underside of the PCB**

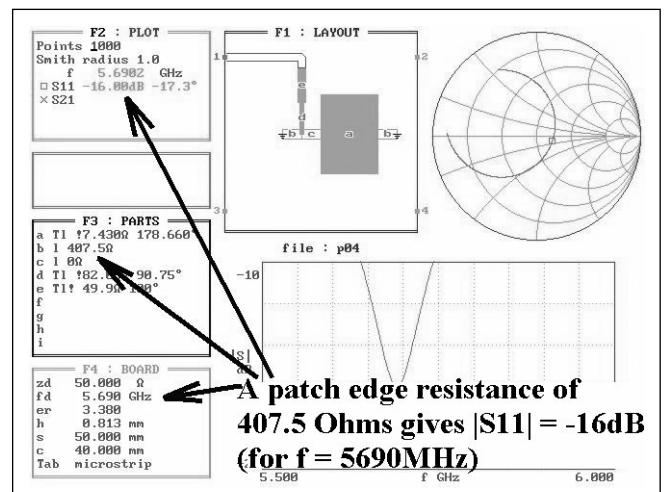

**Fig 17.9: PUFF simulation showing the patch edge resistance of 407.5Ω and  $|S_{11}|$  of -16dB**

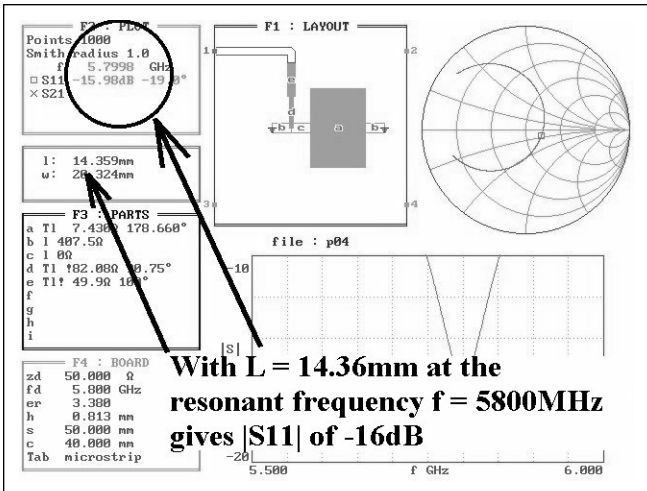

Fig 17.10: Changing the design frequency to 5800MHz gives a length of 14.36mm

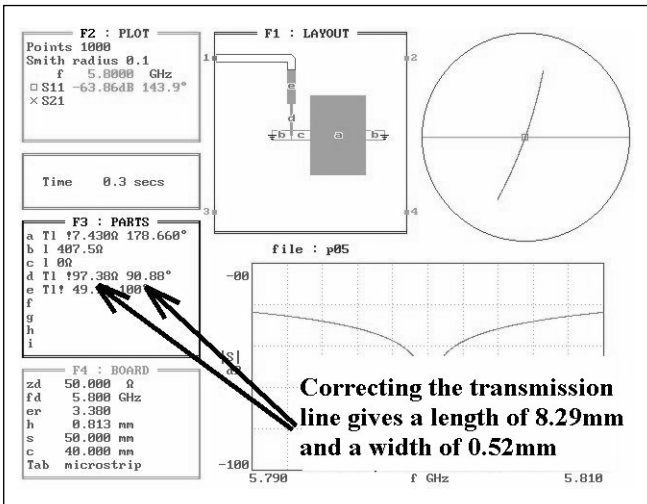

Fig 17.11: Correcting the matching transformer

frequency. It can be seen from Fig 17.10 that for this the length must be reduced to 14.36mm - consequently, shortened by 0.29mm! Thus, in the printed circuit board CAD system, the length used for the initial design of 13.39mm is reduced to 13.39mm - 0.29mm = 13.1mm. The patch width, naturally, remains at 20.32mm.

All that remains is the final change - correcting the  $\lambda/4$  transformation line to obtain better values for the matching of the measured - 16dB. This is also a very easy matter for PUFF, and the result can be seen in Fig 17.11. The new values required are: length = 8.29mm and width = 0.52mm. The required open-end extension for each side must be added to this. For the patch connection, the value of 0.41mm used previously is still valid, but something is altered on the feed side:

$$\Delta L = \left(1 - \frac{0.52}{1.89}\right) \times 0.37 = 0.27\text{mm}$$

The transformation line, therefore, has a width of 0.52mm and a length of 8.29mm + 0.41mm + 0.27mm = 8.97mm. Test readings on a second prototype are shown in Fig 17.12.

The design was also evaluated with two other simulation programs, Mstrip40 and Sonnet Lite, descriptions of these and/or projects using them can be found in VHF Communications [6] and [7].

Sonnet was used on the radiating patch, in order to re-check the resonance frequency and also to investigate the matter of the much higher radiation resistance. Using an online menu made it easy to use this program, but it is important to pay heed to the rules of simulating such antenna structures in the Sonnet manual. It is essential to obtain (free) the additional license for extending the maximum usable PC working memory to 16 megabytes, in order to carry out the simulation successfully. Fig 17.13 shows the Sonnet editor screen with the selected box and cell dimensions, together with the new 'Quick Start Guide'. Owing to the restrictions on the Lite version, the transformation line is simply omitted and replaced by a 50-ohm power feed taken right up to the box wall. The actual radiation resistance of the antenna can then be determined easily and directly from the reflection factor determined in this way. This is how to do it:

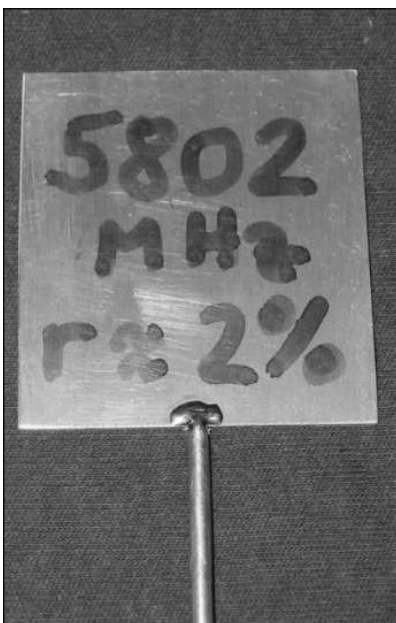

Fig 17.12: A good test result with this antenna

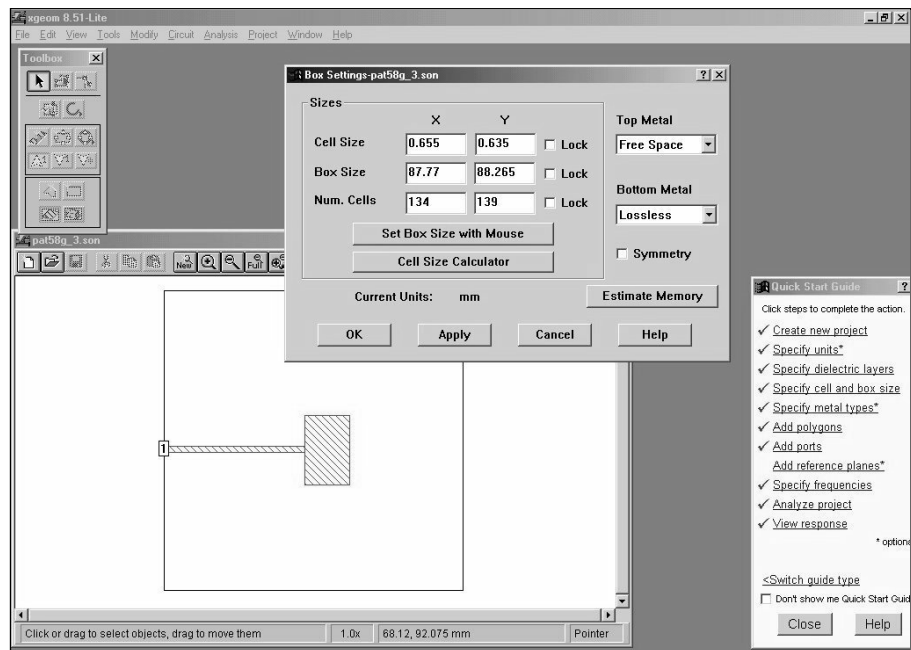

Fig 17.13: Using the Sonnet-Lite simulator for the patch antenna

The simulation result can be seen in Fig 17.14, with a resonance of 6.03GHz and  $|S_{11}| = -4.4\text{dB}$ . This gives a reflection factor of:

$$r = \log \frac{-4.4\text{dB}}{20\text{dB}} = 0.60$$

Because a  $50\Omega$  feed is being used, it is necessary to reduce the circuit length in the Smith diagram until resistances exceeding  $50\Omega$  are arrived at on the real axis. Then, in accordance with the following relationship, the total resistance on the patch edge is obtained:

$$R = \frac{1+r}{1-r} \cdot Z = \frac{1+0.6}{1-0.6} \cdot 50\Omega = 200\Omega$$

Consequently, each radiating edge is affected by a radiation resistance of  $400\Omega$ . Compared with the measured value of  $407.5\Omega$ , this is an extremely satisfactory result, and thus confirms the validity of the measurement. The resonance frequency was simply predicted too high, with an error of:

$$\frac{6030\text{ MHz} - 5800\text{ MHz}}{5800\text{ MHz}} \cdot 100\% = 3.96\%$$

For a comparison simulation, entering the cell data used for Sonnet into the *mstrip40* program gives precisely this resonant frequency, but with rather larger discrepancies of approximately 10 to 15% in the radiation resistance.

Nowadays, the most modern design aids are available, even to private developers without an expensive industrial scale test rig, and at reasonable cost.

**SLOT ANTENNA**

The slot antenna that has become known in the amateur world as the *Alford slot* actually derives from work by Alan D Blumlein of London, and is detailed in his patent number 515684 dated 7 March 1938. The work by Andrew Alford was carried out during the mid 1940s and 50s, and not applied to microwave bands but to VHF/UHF broadcasting transmitters in the USA.

Development by M Walters, G3JVL, was carried out during 1978 when designs for the GB310W 1.3GHz beacon were being investigated. The initial experiment was carried out at 10GHz as the testing was found to be much easier, especially when conducted in a relatively confined space. A rolled copper foil cylinder produced results close to those suggested in the original work. Initially, it was thought that the skeleton version would be best used at the lower frequencies only. However, several models for use on 144MHz have been constructed and they performed very well, but the design was, at the time, not regarded by G3JVL as being of interest.

Further developments have resulted in working models being constructed for the 50MHz, 432MHz, 900MHz and 1.3GHz bands. However, some aspects were not easy to explain and valuable assistance was provided by G3YGF. This assistance provided more than just an explanation for the fact that early skeleton versions worked at a lower than designed frequency. A working operational theory was developed as a direct result, along with a better understanding of the strange effects that were observed.

The 2.3GHz version developed by G3JVL fulfils the need for an omni directional horizontally polarised antenna. This makes it particularly useful for beacons, fixed station monitoring purposes and mobile operation. Mechanical details of this antenna are shown in Fig 17.15. The prototype was made from 22mm outside diameter copper water pipe. Material is removed from one part of the tubing to produce a slotted tube with an outside diameter of 18.5mm and a slot width of 2.6mm. To ensure circularity the

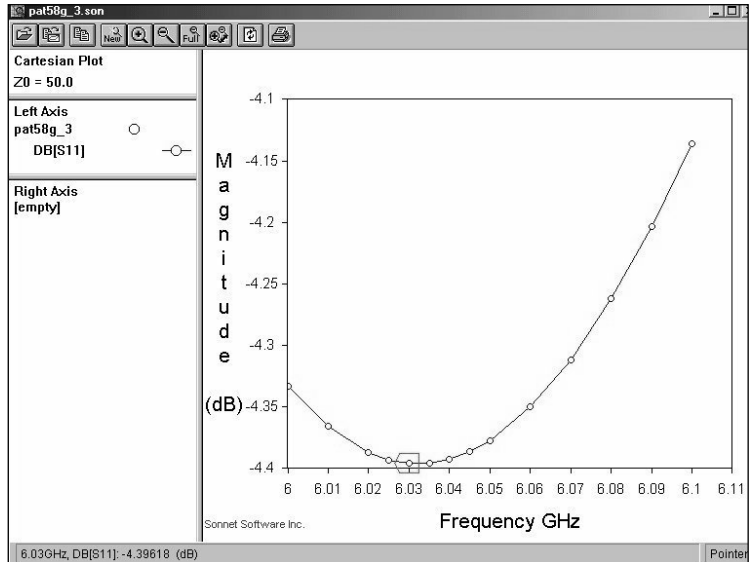
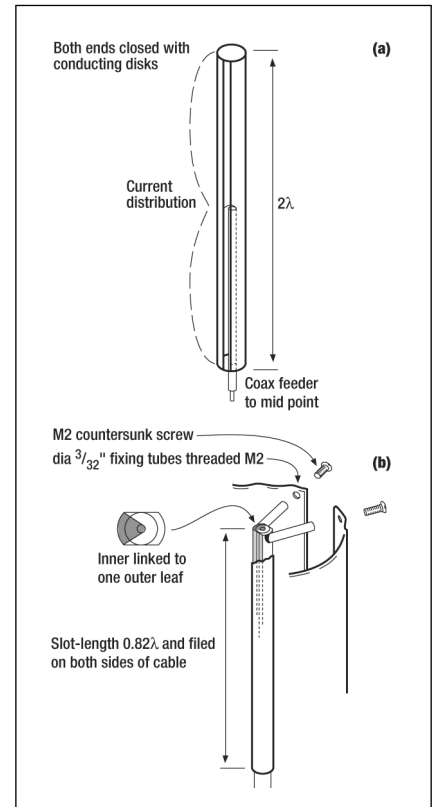

Fig 17.14: Simulation results from Sonnet-Lite

tube is best formed around a suitable diameter mandrel. Small tabs are soldered at the top and bottom of the tube to define the slot length of 229mm. A plate is soldered across the bottom of the tube to strengthen the structure.

The RF is fed via a length of 0.141in (3.6mm) UT-141 semi rigid coaxial cable up the centre of the tube to the centre of the slot via a 4:1 balun constructed at the end of the cable. The detailed construction of the balun is shown in Fig 17.15. The two diametrically opposite slots are cut carefully using a small hacksaw with a new blade. The inner and outer of the cable are shorted using the shortest possible connection and the balun is attached to the slot using two thin copper foil tabs. If suitable test gear is available, the match of the antenna can be optimised by carefully adjusting the width of the slot by squeezing

Fig 17.15: Construction of the 2.3GHz Alford slot antenna using a dual slotted cylinder. The feed point impedance is  $200\Omega$ . (a) Dimensions for 2,320MHz are: slot length 280mm, slot width 3mm, tube diameter 19mm by 18SWG. (b) Construction of a suitable balun. The balun slots are 1mm wide and 26mm long



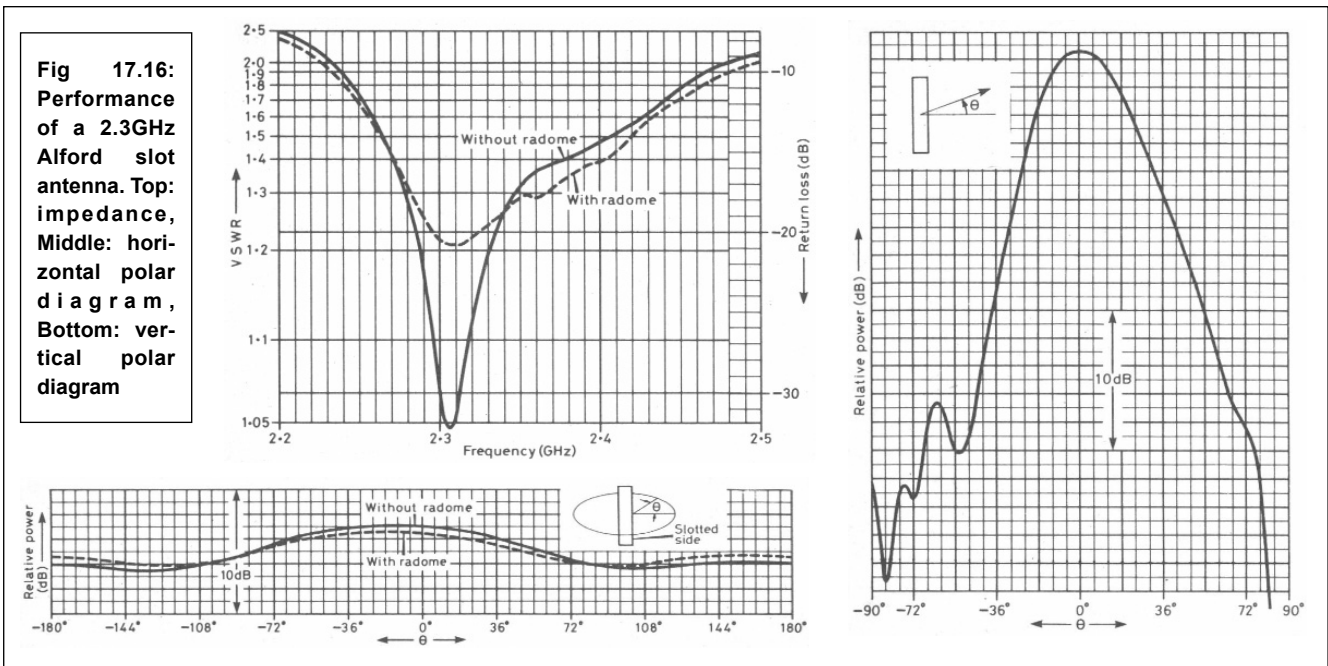

the tube in a vice, or by prising the slot apart with a small screwdriver. Typical antenna characteristics are shown in Fig 17.16. The gain of the antenna has been measured to 6.4dBi.

**HELICAL ANTENNA**

Paolo Pitacco, IW3QBN, designed this array of 4 x 16 turn helix antennas for 2402MHz [8]. Such a project is an interesting challenge for design, manufacture and testing. The designer had no space for a parabolic reflector and required easy mounting and dismounting in case of strong wind. The idea was to design a system capable of operating as a satellite and terrestrial antenna with discrete gain, good capture area and rapid installation. As a starting point a simple 16-turn helix antenna [9] was used to hear signals from the DOVE satellite (2401MHz), and to work with home made ATV systems. The endpoint is an array of four of these helices, shown in Fig 17.17.

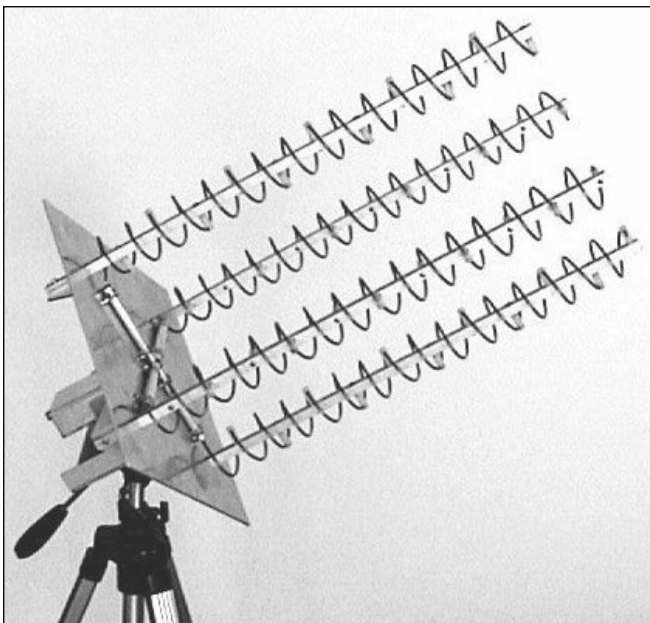

Fig 17.17: The completed 4 x 16 turn helical antenna for 2402MHz

Radio amateurs today have many 'ready to use' computer programs available for helical antenna design, from simple DOS to complex Windows or Linux applications. It is possible to choose from any of the following techniques:

- Reproduce the design by G3RUH [10]
- Make a new design using KA1GT [11] program
- Use Peter Ward's Excel worksheet, 'RF2'
- Follow design formulas from antenna engineering literature [12 & 13]

This excludes all commercial and costly programs. A mix of these ways was followed to check the results from outputs of several programs, and validate and refine using formulas [12]. The same input data (central frequency, number of turns and mechanical dimension) were used in each case.

The design was centred on 2402MHz, to obtain sufficient bandwidth to cover AO-40 and ATV frequencies. Using this centre frequency, a support diameter of 38mm was chosen, together with 31mm spacing between turns. Copper wire of 3mm diameter was used because it is self supporting without the need for any type of plastic tube which would cause up to 15% detuning of the helix due to dielectric action.

Matching a single helix is not difficult. It is possible to achieve a broadband match without use of a network analyser or other measuring instruments, but multiple helix arrays are more difficult. Multiple antennas require a coupling system and matching to the transmission line, and the first is related to the second.

The aperture area of each antenna must be evaluated, and a method found to couple the array to a single cable.

There are four methods:

- 1) Each antenna matched to 50Ω with a 4:1 coupler to the feeder
- 2) Unmatched (Z~140Ω) with a coaxial quarter-wavelength transformer and a 4:1 coupler to the feeder
- 3) Unmatched (Z~140Ω) with a quarter-wavelength wireline transformer to the feeder
- 4) Unmatched (Z~140Ω) with a coaxial quarter-wavelength transformer to the feeder

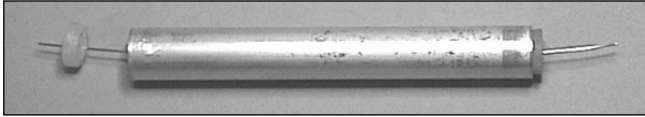

**Fig 17.18: Quarter wavelength transformer for 2402MHz 4 x 16 turn helical antenna**

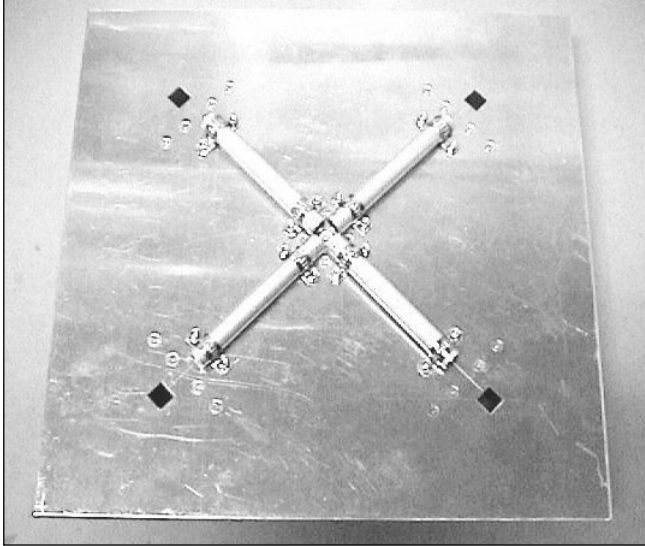

**Fig 17.19: Mounting of the four quarter wavelength transformers for 2402MHz 4 x 16 turn helical antenna**

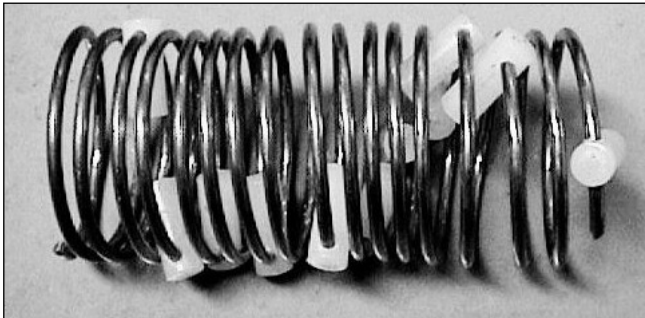

**Fig 17.20: Fitting spacers onto wound helix for 2402MHz 4 x 16 turn helical antenna**

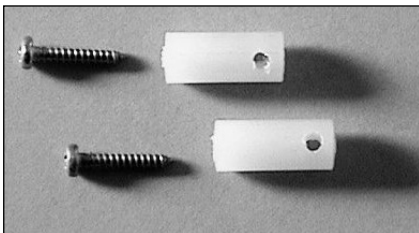

**Fig 17.21: Spacers for helix of 2402MHz 4 x 16 turn helical antenna**

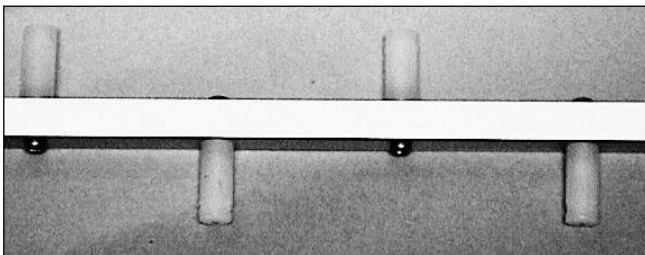

**Fig 17.22: Aluminium support tube for 2402MHz 4 x 16 turn helical antenna**

Solution 1 is easy and is used by G6LVB. Good connectors and cable, and great precision is needed to make four equal helix antennas and cables.

Solution 2 is difficult and no longer used. Mechanical tools and a lot of connectors and cable are needed to make a good transformer.

By using Solution 3, the helix antennas and feeder can be matched in a single pass as a quarter-wavelength transformer with an output impedance equal to 4 x 50Ω is easy, but a wire-line is a potential antenna.

Solution 4 has the advantages of 3, but by using coaxial line you avoid any problem of radiation and the matching line has a more stable impedance. It is a mechanically complex solution, but requires only one connector.

For this project, Solution 4 was chosen, and this drove subsequent mechanical and electrical issues. The helices must be placed at the correct spacing, and a quarter wavelength transformer must be constructed. For 2402MHz, λ is 12.48cm and λ/4 is 3.12cm, but calculations indicate an aperture area of 1.4λ or 17.5cm. A mechanical solution had to be found, using an odd multiple for quarter wavelength, exactly 3λ/4 (93mm) to maintain transformation properties and distance between helices.

Impedance matching with coaxial transformer is straightforward when mechanical machining isn't a problem, using the equation:

$$Z_m = \sqrt{Z_a \times (Z_l \times N_a)} \tag{1}$$

Where  $Z_a$  is the antenna impedance,  $N_a$  is the number of antennas,  $Z_l$  is the impedance of main feeder and  $Z_m$  the required impedance for a match.

Using equation below, it is possible to determine tube and conductor diameter to build the matching section.

$$Z_{\text{coax}} = \frac{138}{\sqrt{\epsilon_r}} \cdot \log\left(\frac{D_g}{D_p}\right) \tag{2}$$

Where  $D_g$  stands for inner diameter of tube,  $D_p$  is diameter of wire,  $\epsilon_r$  is 1.001 for air).

Because the computed helix impedance is 153Ω, a characteristic impedance of 173Ω is needed for this line. The quarter wavelength transformer was made from a commercially available aluminium tube with an external diameter of 12mm (10mm inside), and a 0.6mm diameter silvered copper wire. This represented a good compromise (about 170Ω).

The wire is held in position with a couple of thin (3mm) centre drilled nylon plugs, this means the transformer's dielectric will be near that of air (see Fig 17.18).

All four transformers are locked in position (on the upper side of the reflector) by means of two U-shaped brackets also used as a ground connection. One side is soldered to an N connector (see Fig 17.19). The reflector plate is a made of a 3mm thick square of aluminium sheet with 30cm sides.

Each helix is made with 3mm diameter copper wire, wound on a 35mm diameter support, then gently relaxed and loaded using 11 spacers (every 1.5 turns), as shown in Fig 17.20. The spacers are small cylinders of nylon, 20mm long and 8mm diameter, each pre-drilled with a 3.2mm hole 15.6mm from the bottom (Fig 17.21). The first spacer is located at the end of the helix and last, one turn before the feed point. The spacers are subsequently locked on a square aluminium tube (10mm side, 1mm depth) pre-drilled with 3mm holes at distances of 47mm (one each 1.5 turns) as shown in Fig 17.22. This tube, which is 57cm long, has no effect on performance, and is used to hold the helix in position by means of L-shaped aluminium brackets (measuring 25 x 50mm).



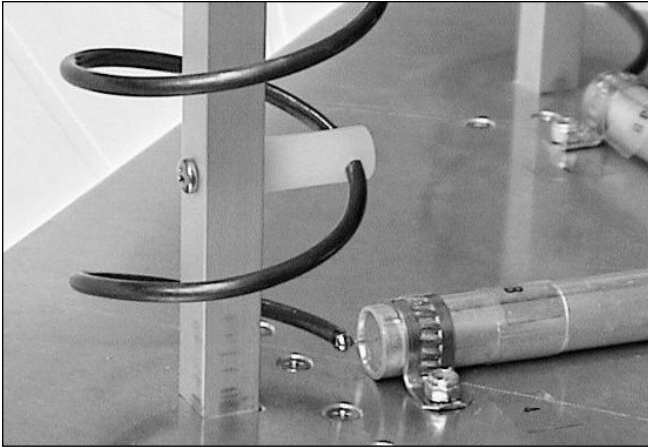

Fig 17.23: Close up view of connection to quarter wavelength transformer for 2402MHz 4 x 16 turn helical antenna

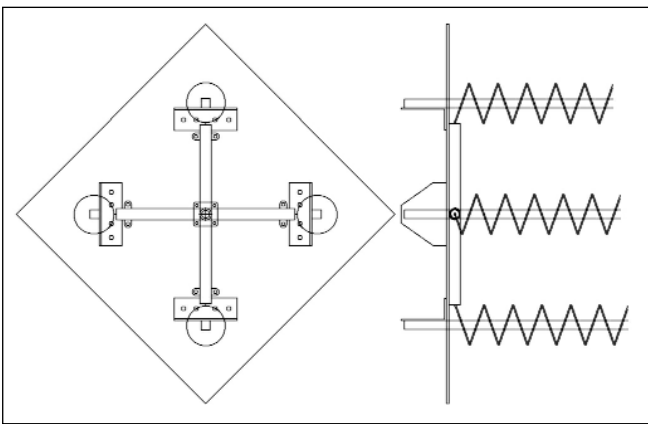

Fig 17.24: Complete mechanical drawing for 2402MHz 4 x 16 turn helical antenna

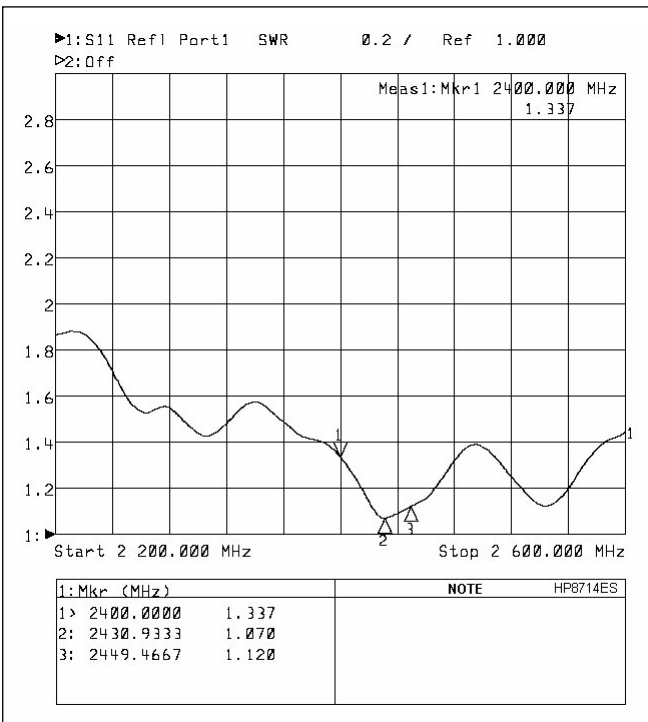

Fig 17.25: Results for 2402MHz 4 x 16 turn helical antenna measured on a network analyser

Another U-shaped bracket is used to hold converters, preamplifiers or other devices, and as a mounting point (eg a tripod).

All helices are wound in the same direction (counter clockwise as seen from rear) in order to maintain the phase of the feed point. Fig 17.23 shows the electrical and mechanical connection between the helix and the coaxial transformer. Attention should be given to soldering the inner transformer conductor; pre-solder the 3mm copper wire beforehand. Fig 17.24 is a complete mechanical drawing of this array.

The first measurement was made with the aid of an Agilent E8714ES Network Analyser, and the results were close to what was expected as shown in Fig 17.25. A low SWR was obtained on 2430MHz (near the centre of S band), but the antenna gives good results over the entire band. Other lengths of transformer (92 and 94 mm respectively) have been tried, but 93mm represents the best compromise for amateur use. The calculated gain is 18dB (including losses), and tests on AO-40 signals demonstrate this figure. A comparison was made with a 80cm dish with 3 turn helix, and this gave 6-8 dB higher gain.

## YAGI ANTENNAS

### Wide Band Yagi for 23cm

Noel Hunkeler, F5JIO, designed an array of six half-wave dipoles with a reflector plane for a 23cm packet radio link [14]. It provides 10dBd gain and an SWR not exceeding 1.1:1 throughout the band. Curtains of phased dipoles have been used by amateurs since before WWII, examples are shown in the 1937 Jones antenna handbook. F5JIO consulted *Rothammel*, the German antenna bible, which gives the following guidelines for the reflector plane:

*For best F/B ratio, it should extend at least a half wave beyond the perimeter of the curtain on all sides. If made of wire mesh instead of solid sheet to reduce windage, the wire pitch should be  $\lambda/20$  or less. A reflector plane spaced  $5\lambda/8$  behind the radiator adds maximum gain, up to 7dB, but a spacing of 0.1 - 0.3 $\lambda$  gives better F/B ratio. If spaced at least 0.2 $\lambda$  behind the curtain, the*

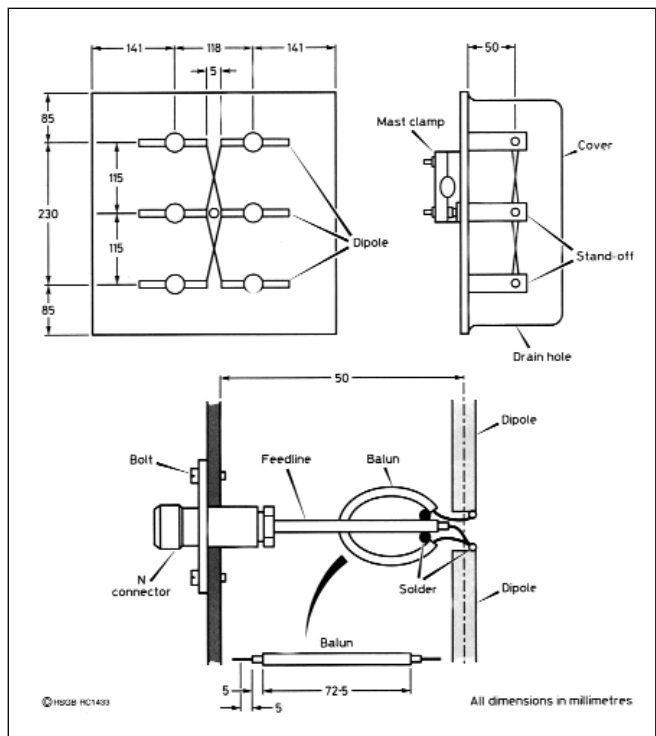
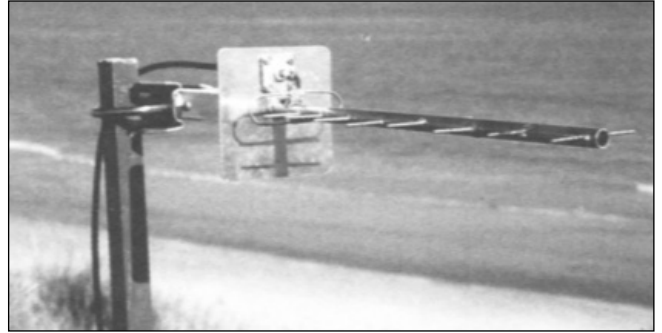

Fig 17.26: Details of wide band Yagi for 23cm



<b>Reflector</b>	400 x 400 (340 min) 2.5 thick aluminium sheet (Qty 1)
<b>Stand-off</b>	Teflon (or PVC) 60L x 20D (Qty 6)
<b>Dipole</b>	Brass, silvered, 108L x 6D (Qty 6)
<b>Rod, phasing</b>	Wire, silvered, 2D (Qty 4)
<b>N connector</b>	(Qty 1)
<b>Feedline</b>	Semi rigid coax, 50 , approximately 4D (Qty 1)
<b>Balun</b>	as above, 92.5L (Qty 1)
<b>Bolt</b>	M3 x 8, SS (Qty 4)
<b>Cover</b>	Plastic food container (Qty 1)
<b>Mast clamp</b>	From TV antenna (Qty 1)



**Table 17.1: Component list for wideband 23cm beam. All dimensions are in mm**

**Fig 17.27: Picture of the 22 element Yagi antenna for the 13cm band**

reflector plane does not affect the feed point impedance of the array.

With the dimensions given in Fig 17.26 and the parts shown in Table 17.1, the feed point impedance of each dipole pair is approximately 600Ω balanced. Three pairs in parallel give 200Ω balanced. The 4:1 re-entrant line balun transforms this to 50Ω, unbalanced. Note that each dipole is supported at its voltage node; hence the standoffs need not be high quality insulators.

For 23cm this antenna is small, so a solid aluminium reflector is practical; this plate supports all other components. Slightly bend the phasing rods so they do not touch at the crossovers. For weather protection, a plastic food container serves as a radome. Its RF absorption seems negligible for our application and it is much cheaper than Teflon. Although precision is required, construction of this antenna is not difficult.

**DL Design Yagi for 13cm**

Leo Lorentzen, OZ3TZ, designed these 10 and 22 element Yagi antennas for 13cm [15]. The design comes from a popular antenna designer, DL6WU, who has been much copied. While very popular, his writings are also courtesy of Prof H Yagi from Japan, dating right back to 1928 (see the Antenna Fundamentals chapters for more on Yagis).

The Danish version of this Yagi (Fig 17.27) is made of standard dimension brass materials, worth mentioning, as you will often see measurements for the materials used that are not in stock at your local metal goods dealer. Common standard dimensions like 2.0, 2.5, 3.0mm etc are off the peg goods, so once the shopping has been done and the brass has been delivered, you're well on your way towards your 13cm antenna project.

The customary practice for brass work is to use good tools. Mark out the antenna boom and check the marking an extra time before positioning the twenty centre punch marks and then drilling twenty 2mm diameter holes for the directors, which first need to be soldered into the boom. Solder the dipole on top of the boom. Fig 17.28 shows the dimensions of the elements and Fig 17.29 shows the detail of the dipole. Drill two 10mm diameter holes in the 80 x 80mm, 1mm brass plate reflector plate, soldering it firmly to the antenna boom as well.

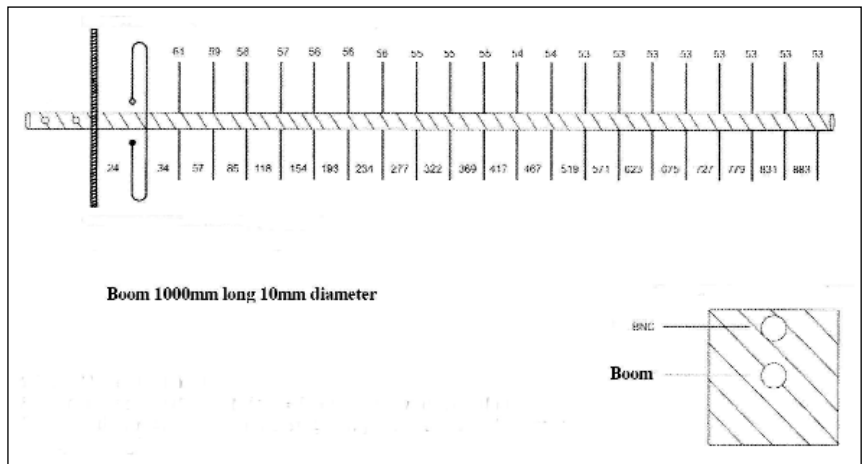

**Fig 17.28: Element dimensions for the 22 element 13cm Yagi**

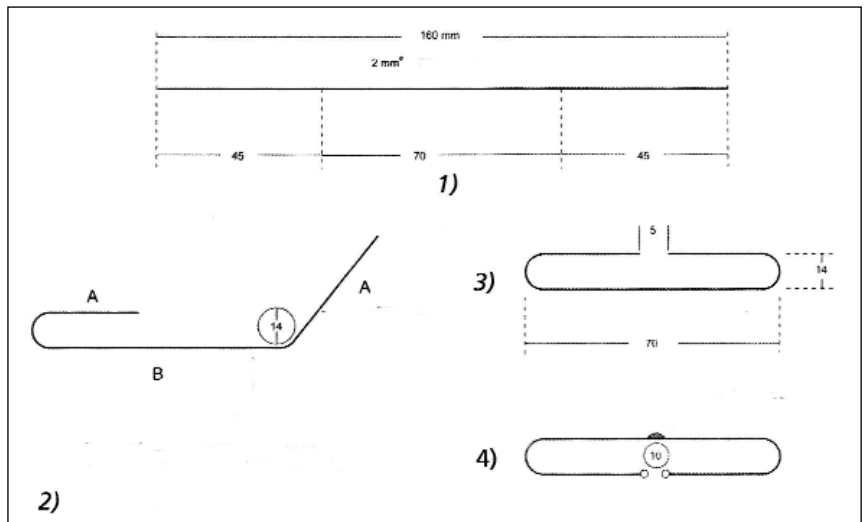

**Fig 17.29: Details of the dipole for the 22 element 13cm Yagi**

Behind the reflector, drill two 4mm diameter holes, spaced 75mm apart. On top of the holes two 4mm diameter nuts are soldered so that the antenna can be secured to a mast fixture or something else. Mount a BNC socket in the reflector plate to accept the 65mm RG178s from the dipole/balun, see Fig 17.30.

The really important thing is to solder the screen directly onto the antenna socket and allow the screen to go right up to the inside pin on the BNC socket, where the inner conductor in the cable will be soldered. If the antenna is to be sited outdoors, Araldite can be used to make 50Ω cabling etc watertight.

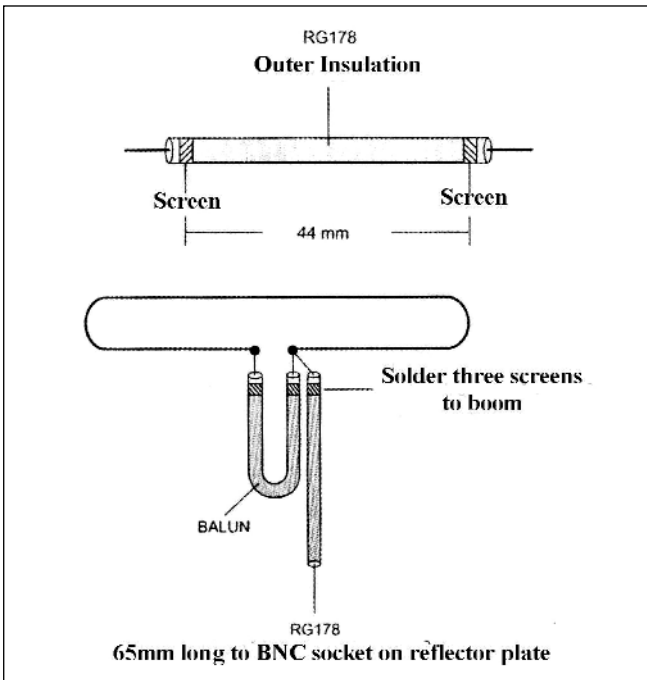

Fig 17.30: Details of the balun for the 22 element 13cm Yagi

The finished antenna fares well in practical use. To measure the gain, an absolutely stable test signal was received on a half-wave dipole connected to a 13cm converter. With the dipole antenna, an approximately S1 signal was received. A 10 element yagi was then substituted for the dipole and an approximately S3 signal was received. Then the 22 element antenna was connected, and an impressive S7 signal was received. According to the original designer of the antenna, a boom length of seven wavelengths and approximately 20 elements makes for something over 15dBd.

### Quad Loop Yagi for 9cm

This antenna was originally designed by M Walters, G3JVL. The design is shown in Fig 17.31 with the critical dimensions shown in Table 17.2. The design is a scaled version of the 1,296MHz design, adapted to the narrow band segment at 3,456MHz. There are 61 directors giving a boom length of 2m. The construction of the antenna is quite straightforward providing care is taken in the marking out process. Measurements should be made from a single point or datum. In marking the boom for instance, measurements of the position of the elements should be made from a single point rather than marking out individual spacings.

All elements are made from 1.6mm diameter welding rod cut to the lengths shown in the table, then formed into a loop as shown in Fig 17.32a. The driven element is brazed to a M6 x 25 countersunk screw drilled 3.6mm to accept the semi rigid coaxial cable. All other elements are brazed onto the heads of M4 x 25 countersunk screws. All elements, screws and joints should be protected with a coat of polyurethane varnish after assembly. If inadequate attention is paid to weatherproofing the antenna, its performance will gradually deteriorate as a result of corrosion.

<b>Boom:</b>			
Boom diameter	12.5mm od		
Boom length	2.0m		
Boom material	aluminium alloy		
<b>Elements:</b>			
Driven element	1.6mm diameter welding rod		
All other elements	1.6mm diameter welding rod		
<b>Reflector size:</b>			
Reflector plate	52.4 x 42.9mm		
<b>Element lengths:</b>			
Length 1 (mm) (see Fig 17.32a):	Directors 21-30	78.2	
Reflector loop	Directors 31-40	76.1	
Driven element	Directors 41-50	75.1	
Directors 1-12	Directors 51-60	74.6	
Directors 13-20		81.2	
<b>Cumulative element spacings (mm):</b>			
RP	0.0	RL	29.5
DE	38.6	D1	49.2
D2	57.2	D3	74.1
D4	91.1	D5	103.0
D6	125.0	D7	158.9
D8	192.8	D9	226.7
D10	260.6	D11	294.5
D12	328.4	D13	362.3
D14	396.2	D15	430.1
D16	464.1	D17	498.0
D18	531.9	D19	565.8
D20	599.7	D21	633.6
D22	667.5	D23	701.4
D24	735.3	D25	769.2
D26	803.1	D27	837.0
D28	871.0	D29	904.9
D30	938.8	D31	972.7
D32	1006.6	D33	1040.5
D34	1074.4	D35	1108.3
D36	1141.2	D37	1176.1
D38	1210.0	D39	1244.0
D40	1277.9	D41	1311.8
D42	1345.7	D43	1379.6
D44	1413.5	D45	1447.4
D46	1481.3	D47	1515.2
D48	1549.1	D49	1583.1
D50	1617.0	D51	1650.9
D52	1684.8	D53	1718.7
D54	1752.6	D55	1786.5
D56	1820.4	D57	1854.3
D58	1888.2	D59	1922.1
D60	1956.1	D61	1990.0

Table 17.2: Dimensions of 3.4GHz loop quad

Fig 17.31: The 9cm quad loop Yagi. Dimensions are shown in Table 17.2

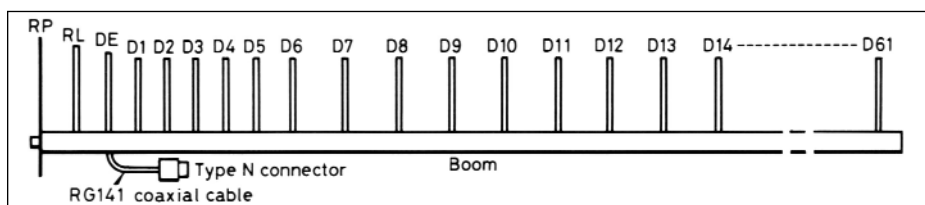

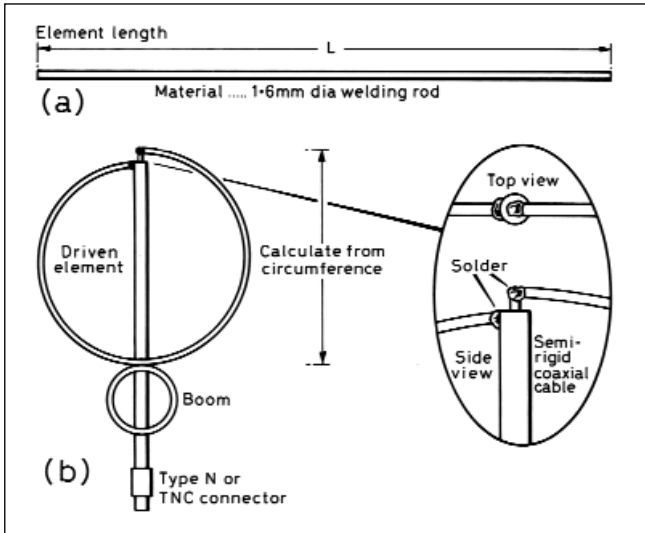

**Fig 17.32: (a) Detail of element construction. (b) Assembly of the driven element for the 9cm quad loop Yagi**

Provided the antenna is carefully constructed, its feed impedance will be close to 50Ω. If a suitably rated power meter or impedance bridge is available, the match may be optimised by carefully bending the reflector loop toward or away from the driven element.

The antenna can be mounted using a suitable antenna clamp. It is essential that the antenna be mounted on a vertical support, as horizontal metalwork in its vicinity can cause severe degradation in its performance.

## HORN ANTENNAS

### 3cm Horn

Large pyramidal horns can be an attractive form of antenna for 10GHz and above. They are fundamentally broadband devices showing virtually perfect match over a wide range of frequencies, certainly over an amateur band. They are simple to design, tolerant of dimensional inaccuracies during construction and need no adjustment. Their gain can be predicted within a dB or so (by simple measurement of the size of the aperture and length) which makes them useful for both the initial checking of the performance of systems and as references against which other antennas can be judged. Their main disadvantage is that they are bulky compared with other antennas having the same gain.

Large (long) horns, such as that illustrated in Fig 17.33, result in an emerging wave which is nearly planar and the gain of the horn is close to the theoretical value of  $2\pi AB/\lambda^2$ , where A and B are the dimensions of the aperture. For horns which are shorter than optimum for a given aperture, the field near the edge lags

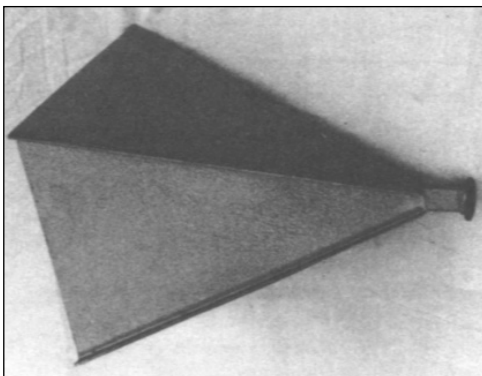

**Fig 17.33: Picture of a large 10GHz horn**

in relation to the field along the centre line of the horn and causes a loss in gain.

For very short horns, this leads to the production of large minor lobes in the radiation pattern. Such short horns can, however, be used quite effectively as feeds for a dish. The dimensions for an optimum horn for 10GHz can be calculated from the information given in Fig 17.34 and, for a 20dB horn, are typically:

- A = 5.19in (132mm)
- B = 4.25in (108mm)
- L = 7.67in (195mm)

There is, inevitably, a trade off between gain and physical size of the horn. At 10GHz this is in the region of 20dB or perhaps slightly higher. Beyond this point it is better to use a small dish. For instance a 27dB horn at 10GHz would have an aperture of 11.8in (300mm) by 8.3in (210mm) and a length of 40.1in (1,019mm) compared to a focal plane dish that would be 12in (305mm) in diameter and have a length of 3in (76mm) for the same gain.

Horns are usually fabricated from solid sheet metal such as brass, copper or tinplate. There is no reason why they should not be made from perforated or expanded metal mesh, provided that the size and spacing of the holes is kept below about  $\lambda/10$ . Construction is simplified if the thickness of the sheet metal is close to the wall thickness of WG16, ie 0.05in or approximately 1.3mm. This simplifies construction of the transition from the waveguide into the horn. The geometry of the horn is not quite as simple as appears at first sight since it involves a taper from an aspect ratio of about 1:0.8 at the aperture to approximately 2:1 at the waveguide transition. For a superficially rectangular object, a horn contains few right angles, as shown in Fig 17.35 an approximately quarter scale template for a nominal 20dB horn at 10.4GHz. If the constructor opts to use the one piece cut and fold method suggested by this figure, it is strongly recommended that a full sized template be drafted on stiff card that can be lightly scored to facilitate bending to final form. This will give the opportunity to correct errors in measurement before transfer onto sheet metal and to prove to the constructor that, on folding, a pyramidal horn is formed!

The sheet is best sawn (or guillotined) rather than cut with tin snips, so that the metal remains flat and undistorted. If the

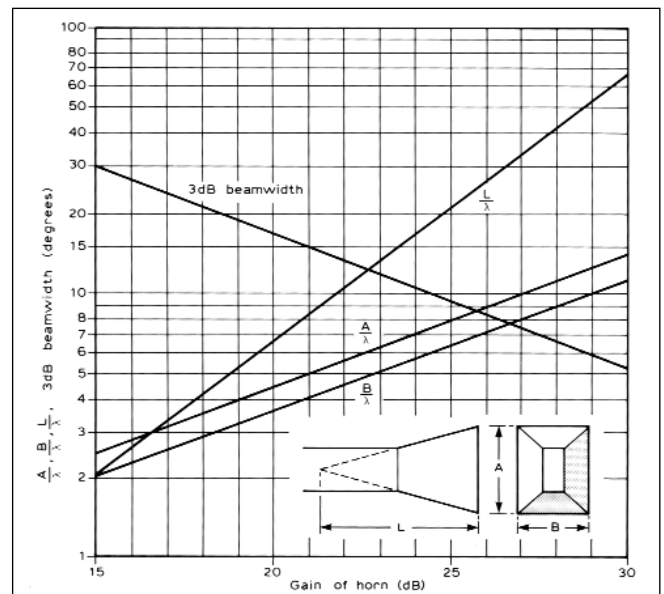

**Fig 17.34: Horn antenna design chart**

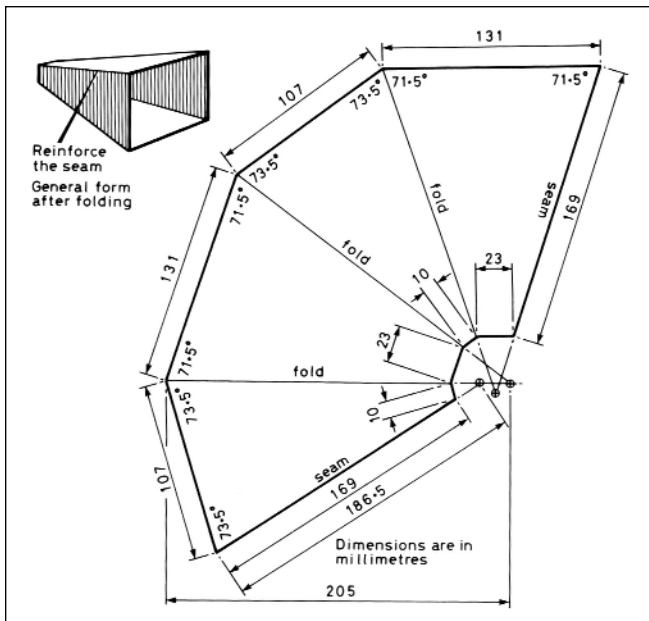

**Fig 17.35: Dimensioned template for single piece construction of a 20dB horn**

constructor has difficulty in folding sheet metal, then the horn can be made in two or more pieces, although this will introduce more soldered seams which may need jiggging during assembly and also strengthening by means of externally soldered angle pieces running along the length of each seam. Alternative methods of construction are suggested in **Fig 17.36**.

It is worth paying attention to the transition point that should present a smooth, stepless profile. The junction should also be mechanically strong, since this is the point where the mechanical stresses are greatest. For all but the smallest horns, some form of strengthening is necessary. One simple method of mounting is to take a short length of Old English (OE) waveguide, which has internal dimensions matching the external dimensions of WG16, and slitting each corner for about half the length of the piece. The sides can then be bent (flared) out to suit the angles of the horn and soldered in place after carefully positioning the OE guide over the WG16 and inserting the horn in the flares. One single

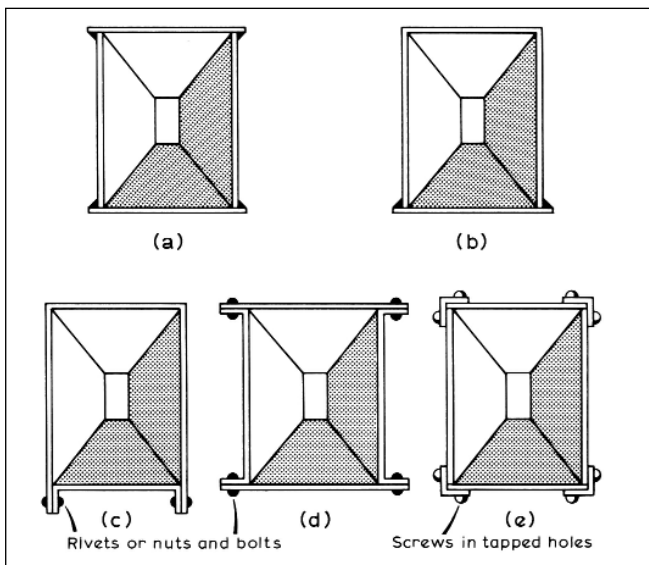

**Fig 17.36: Alternative construction methods for constructing horn antennas**

**Fig 17.37: Dimensions of horn antenna for 24GHz**

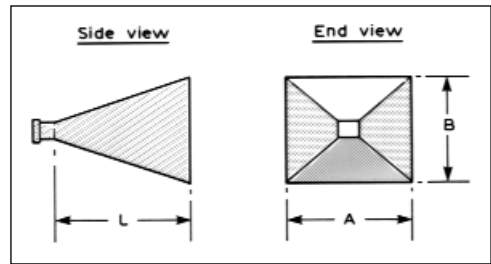

**Table 17.3: Gain of 24GHz horn antennas**

Gain (dB)	Beamwidth (degrees)	Length (mm)	A (mm)	B (mm)
15	30	26	31	25
20	17	81	55	45
25	9	270	98	79
30	5	819	174	141

soldering operation will then fix both in place. After soldering, any excess of solder appearing inside the waveguide or throat of the horn should be carefully removed by filing or scraping. The whole assembly can be given a protective coat of paint.

An alternative method would be to omit the WG16 section and to mount the horn directly into a modified WG16 flange. In this case the thickness of the horn material should be a close match with that of WG16 wall thickness and the flange modified by filing a taper of suitable profile into the flange.

Whichever method of fabrication and assembly is used, good metallic contact at the corners is essential. Soldered joints are very satisfactory provided that the amount of solder in the horn is minimised. If sections of the horn are bolted or riveted together, it is essential that many, close spaced bolts or rivets are used to ensure good contact. Spacing between adjacent fixing points should be less than a wavelength, ie less than 30mm.

**24GHz Horn Antenna**

A 24GHz horn is a very easy antenna to construct, as its dimensions are not critical and it will provide a good match without any tuning. The dimensions, as per **Fig 17.37**, for optimum gain horns of various gains (at 24GHz) are shown in **Table 17.3**. Above 25dB the horn becomes very long and unwieldy and it becomes more practical to use a dish.

Suitable materials are PCB material, brass or copper sheet, or tin plate. If PCB material is used, the doubled-sided type will enable the joints to be soldered both inside and out for extra strength. An ideal source of tin plate is an empty oil can.

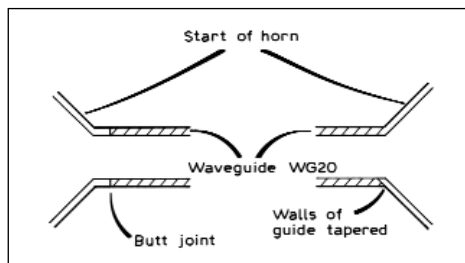

**Fig 17.38: Joining a 24GHz horn directly to a waveguide**

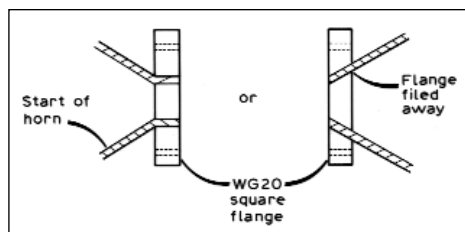

**Fig 17.39: Joining a 24GHz horn directly to a flange**

The transition from the guide to the horn should be smooth. Use either a butt joint, or file the waveguide walls to a sharp edge, see Fig 17.38. The material should be cut to size and then soldered together and onto the end of a piece of waveguide. Alternatively the horn may be coupled directly to the inside of a flange. In this case the material should be the same thickness as the waveguide would be and it is bent as it enters the flange, or the flange may be filed to be part of the taper, see Fig 17.39.

**DISH ANTENNAS**

**Offset Feed Parabolic Dish [16]**

The spread of consumer satellite TV means that good offset feed dishes can be obtained easily and for reasonable prices. These can be found on eBay and are known as TVRO (TV Receive Only) or DSS (Digital Satellite System) antennas with sizes from 45cm (18in). They can offer excellent performance up to at least 10GHz.

An offset feed dish antenna has a reflector that is a section of a normal parabolic reflector, as shown in Fig 17.40. If the section does not include the centre of the dish, then none of the radiated beam is blocked by the feed and support structure. For small dishes, feed blockage in an axial feed dish causes a significant loss in efficiency. Thus, we might expect an offset feed dish to have higher efficiency than a conventional dish of the same aperture.

In addition to higher efficiency, an offset feed dish has another advantage for satellite reception. The dish in Fig 17.41, aimed upward toward a satellite, has its feed pointing toward the sky. A conventional dish would have the feed above it, pointing toward the ground, as shown in Fig 17.42. Any spillover from the feed pattern of the conventional dish would receive noise from the warm earth, while spillover from the offset dish would receive less noise from the cool sky. Since a modern low noise receiver has a noise temperature much lower than the earth, the conventional dish will be noisier. This is the G/T, the offset dish offers higher gain, G, since the efficiency is higher, plus reduced noise temperature, T, so both terms in the G/T ratio are improved. The higher gain means more signals may be received from a source, and the lower noise temperature means that less noise accompanies it, so a higher G/T offers a higher signal-to-noise ratio

The real incentive in the USA to use an offset feed dish was provided by Zack Lau, KH6CP [17] (now W1VT) who pointed out that the 18in RCA DSS dishes were available by mail order for about \$13. He ordered a dish and a mounting bracket to see if he could figure out how to use one at 10GHz. When it arrived, it wasn't obvious where the feed point should be, so he took a trip to a local discount store to see the system on display.

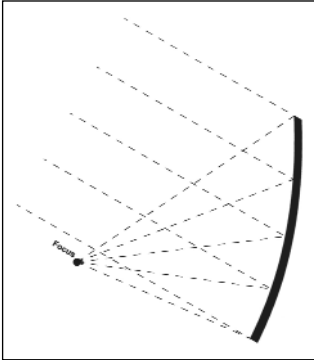
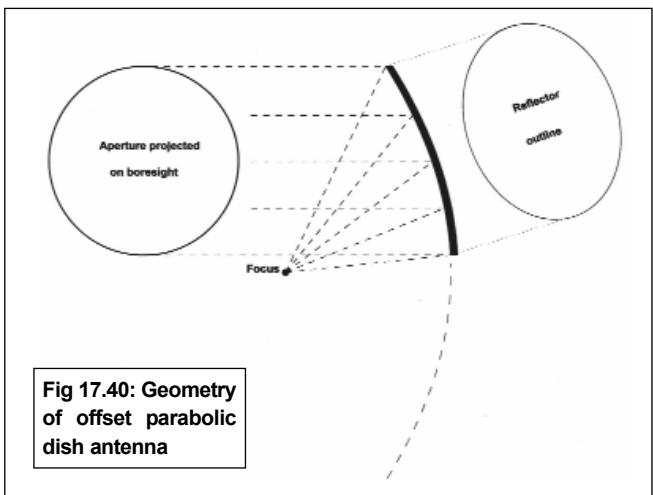

Fig 17.41: Offset parabolic dish antenna aimed at a satellite

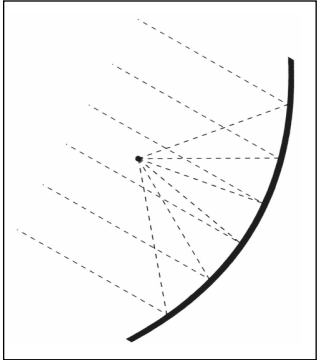

Fig 17.42: Parabolic dish antenna aimed at a satellite

That gave an idea where to put the feed, but not the exact location. The RCA reflector is oval shaped, but Ed, W2TTM, provided the insight that the dish aperture should appear circular when viewed on a bore sight, as shown in Fig 17.40. Thus the dish must be tilted forward for terrestrial operation. The angle, feed point location, and the rest of the dish geometry can be calculated as follows using the Paul Wade, W1GHZ, technique or by reference to [18]:

The geometry of an offset feed dish antenna is a bit more complicated than a conventional dish antenna, but the measurements needed to use one are straightforward. We need to determine the tilt angle of the reflector first, then do some curve fitting calculations for the dish surface, calculate the focal length, and finally determine the focal point in relation to the offset reflector.

One common type of offset parabolic reflector has an oval shape, with a long axis from top to bottom and a shorter axis from side to side. However, if you were in the beam of this antenna, looking down the bore sight, it would appear to be circular, with the feed at the bottom. Tilt the top of the reflector forward, until it appears circular from a distance, and it will be in the correct orientation to operate with the beam on the horizon. The approximate tilt can be determined much more accurately with a simple calculation:

Tilt angle (from horizontal) = arcsin (short axis / long axis)  
 (Note: arcsin is called  $\sin^{-1}$  on some scientific calculators)

For the RCA 18in dish, the short axis is 460mm. (about 18in) and the long axis is 500mm. Therefore, the tilt angle = arcsin (460/500) = 66.9 degrees above horizontal. At 10GHz, one millimeter is sufficiently accurate for most dish dimensions, so using millimeters for calculations eliminates a lot of tedious decimals.

If the offset reflector is not oval, we can still use the same calculation by placing it on the ground with the reflecting surface upward and filling it with water. The surface of the water in the dish should be an oval just touching the top and bottom rims, the other axis of the oval of water is the shorter axis.

The other dimension we need is location and depth of the deepest point in the dish. The deepest point is probably not at the centre, but somewhere along the long axis. Using a straight-edge across the rim for an oval dish, or the water depth for other shapes, locate the deepest point and measure its depth and distance from the bottom edge on the long axis.

For the RCA dish, the deepest point is 43mm deep at 228mm from the bottom edge on the long axis.

When the dish is tilted forward to 66.9° above horizontal, the translated coordinates describe the curve of the long axis by three points:

- 0, 0mm (bottom edge)
- 49.8, 226.6mm (deepest point)
- 196, 460mm (top edge)

If we assume that the bottom edge is not at the axial centre of a full parabola of rotation (the equivalent conventional dish of which the offset dish is a section), but rather is offset from the centre by an amount  $X_0$ ,  $Y_0$ , then all three points must fit the equation:  $4 \times f \times (X+X_0) = (Y+Y_0)^2$

The unknowns are  $X_0$ , and  $Y_0$ , and  $f$ , the focal length. Using these gives three equations and three unknowns, a readily soluble  $3 \times 3$  matrix (actually, the 0,0 point allows reduction to a  $2 \times 2$  matrix, even easier, followed by a simple calculation for  $X_0$  and  $Y_0$ ). Version 2 of the *HDL\_ANT* program [19] will do the calculations.

For the RCA dish, the answers are:

$f = 282.8 \text{ mm} = 11.13 \text{ in}$

$X_0 = 0.1 \text{ mm}$  behind bottom edge

$Y_0 = 11 \text{ mm}$  below bottom edge, so the feed doesn't block the aperture at all.

However, the bottom edge of the dish should be at the centre of the full parabola, so that  $X_0 = 0$  and  $Y_0 = 0$ . Repeating the calculations above with slightly different tilt angles until  $X_0 = 0$  and  $Y_0 = 0$ ; for the RCA dish, the new tilt angle is  $68.3^\circ$  a small change from the original estimate of  $66.9^\circ$ . The focal length is then calculated to be  $291 \text{ mm}$ . Version 3 of the *HDL\_ANT* program will do the improved calculations.

The calculations show the focal length of the dish to be  $280 \text{ mm}$ . If it were a full parabola rather than just an offset section, the diameter would be  $929 \text{ mm}$ , for an  $f/D = 0.31$ . However, a feed horn need only illuminate the smaller angle of the offset section, a subtended angle of about  $78^\circ$ . This subtended angle is the same as a conventional dish with an  $f/D$  of  $0.69$ , so a feed horn designed for a  $0.69 f/D$  conventional dish should be suitable. The G3RPE graph [20] for rectangular feed horns and *HDL\_ANT* were used to design suitable rectangular horns, then two of different lengths were made from flashing copper. *HDL\_ANT* includes an approximation to G3RPE's curves so that the program can design feed horns for both offset and conventional dishes as well as generate templates for constructing them.

Since the actual reflector geometry has an  $f/D$  of  $0.31$ , the focal distance should be quite critical. This dimension is the most critical for dish antenna performance, even more critical for reflectors with smaller  $f/D$ , so the phase centre of the feed should be positioned within a quarter wavelength of the focal point. The RCA dish must be tilted forward to an angle of  $67.9^\circ$  from horizontal for terrestrial operation, with the beam on the horizon. In this orientation, the focal point is level with the lower rim of the dish, so the most of the feed horn and all of the feed mounting structure are out of the beam. To locate the focus accurately, the distance to both the top and bottom of the rim was calculated and a knot tied in a piece of string taped to the rim so that the knot was at the focus when the string is pulled taut, as demonstrated in **Fig 17.43**. Then a sliding plywood holder for the feed horn was made and taped it in place then adjusted so that the knot in the string was at the phase centre of the horn, as shown in **Fig 17.44**. Materials aren't critical when they aren't in the antenna beam!

Where should the feed horn be aimed? On a conventional dish it is obviously at the centre. However, an offset feed is much closer to one edge of the dish, so that edge will be illuminated with much more energy than the opposite edge. There is a long article [21] showing a lengthy analysis of the various aiming strategies and concluded that small variations have little effect, so aiming at the centre of the reflector is close enough.

After all this analysis, it was time to see if the offset dish really works. W1RIL, WB1FKF, N1BAQ, and N1BWT setup an antenna range and made some of the measurements. The RCA dish with a simple rectangular feed horn measured 63% efficiency at



**Fig 17.43:** Using a knot tied in a piece of string to accurately place the feed horn at the focus of an offset dish

$10 \text{ GHz}$ , significantly higher than ever measured with on an  $18 \text{ in}$  conventional dish. Varying the focal distance showed that the calculations were correct and that the dimension is critical.

## Parabolic Preloaded Stressed Dish for Moonbounce

Above  $1 \text{ GHz}$ , the most favourable antenna form has proved to be the parabolic dish, as it combines high gain derived from its unrivaled directivity with low noise pick-up from the ground by well-suppressed sidelobes when properly designed. This is extremely important for EME applications, where every tenth of a dB signal/noise ratio makes the difference to complete a contact. Moreover, the dish can be used for different amateur bands by just changing the feed.

The following description of a lightweight, fully collapsible parabolic dish antenna (**Fig 17.45**) with a diameter of  $4.1 \text{ m}$  is useful for those amateurs interested in moonbounce, who cannot set up a larger dish as a permanent installation due to confinements of their location.

This so-called 'preloaded stressed dish' was developed by Michael Kohla, DL1YMK, and was successfully used in his portable multiband moonbounce DXpeditions to EI, CT3 and TF in 2005-2007 on  $70 \text{ cm}$  to  $13 \text{ cm}$ . The idea of a quick to install, and even quicker to dismantle, dish is based on an earlier article by K2RIW in *QST* magazine [22]. The stressed dish does not use parabolically shaped, preformed struts, but generates the



(close to) parabolic curvature by bending originally straight spokes with guywires fixed to a central point in front of the focal plane. Although the parabolic shape will not be perfect with such a stressed dish,  $f/D$

**Fig 17.45:** Parabolic preloaded stressed dish for moonbounce used by Michael Kohla, DL1YMK, in Iceland



**Fig 17.46: Bush arrangement at the centre of the dish**

ratios up to 0.45 are feasible, which allows circular polarized square feed horns to be used, as described by OK1DFC [23]. This dish was used on 13cm with just such a CP feedhorn made by OK1DFC with surprisingly good performance during the TF/DL1YMK DXpedition.

Except screws and bolts, which are all stainless steel for durability, all other parts are made from aluminium to save weight. This description need not necessarily be followed in every detail; it should just give an incentive to the enthusiastic moonbouncer.

The central part of the dish is the hub that consists of a solid aluminium disc, 350mm diameter and 25mm thick. The centre of the disc has a 32mm hole with a bush welded to the centre. This bush is 70mm long with an outer diameter of 50mm and a 32mm bore. The bush has a dual purpose:

- the central pole used for the feed support is passed through it and fixed with two screws,
- the bush is the axis for a second aluminium disc with a central hole of 50.5mm and a diameter of 350 mm (just the same as the first disk), but only 10mm thick. Details can be seen in **Fig 17.46**.

This second disk is an adapter plate for the two axis rotator system, but, above all, gives essential handling assistance for setting up the dish and fixing the upper mesh segments. It enables the front plate and spokes to be rotated when the four screws that fix it to the adapter plate are not fitted. One person can perform all of the assembly operations (although a helping hand always is welcome). It is not advisable to reduce the thickness of the hub or adapter plate because considerable mechanical stress has to be absorbed by the hub assembly when bending the spokes to the desired f/D ratio.

The thicker hub disc has 18 radial holes on the outer rim, all have a diameter of 12.5mm and a depth of 120mm. These holes will accept the 18 spokes of the dish that consist of 18 aluminium tubes 2000mm x 12mm x 1mm. The angle between the radial holes has to be  $360^\circ / 18 = 20^\circ$ . These holes are preferably drilled on a CNC machine to guarantee symmetry.

A special conical anchor piece was made on a lathe; see **Fig 17.47**, to fix the 18 front guy wires for stressing the spokes to the central feed pole. Again, it has an inner diameter of 30.5mm for the protruding feed support pole, a standard 30mm aluminium tube with 3mm wall thickness for improved rigidity. The face of the cone has 18 screw-threaded eyes for easily fixing the guy wires with little steel hooks. A second identical anchor piece provides the fixing of the rear guy wires to the feed pole. The rear guy wires cannot be omitted under any circumstances because

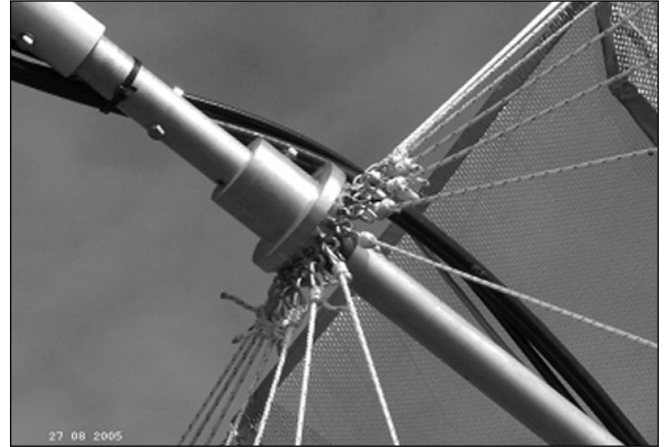

**Fig 17.47: Conical anchor piece for preloaded stressed dish**

experience by the author on his first portable EI DXpedition [24] resulted in an early dish crash induced by high winds from the back of the dish. They will not only stabilise the structure against the wind pressure from the rear, but will also retain the dish's shape at any elevation from the load of the feed pole with the feed horn and preamp attached.

The front guy wires are all equal and about 1930 millimetres long, the ones on the rear are about 2530mm. The exact length is not critical, as long as a dish depth of 450mm can be adjusted giving an f/D of 0.43 at a focal length of 1760mm. Remember:  $f = 16 / (\text{depth} \times \text{diameter})$ . However, they have to be made of a very rigid polymer fibre like Polyester (PET, ie Dacron™) because they must not stretch under stress, nor lengthen in humid conditions (Polyamide absorbs up to 10% w/w of water, therefore is completely unsuitable!).

The front guy wires are fixed to the end of the spokes by means of aluminium dowels (10mm dia x 15mm, see **Fig 17.48**), again with thread eyes at their centre for easy fixing of steel hooks attached to the wires. The dowels can be easily inserted into (and removed from) the open ends of the 12mm spoke tubes. These dowels are strung onto another Dacron line, running through all thread eyes as the circumference of the dish in the stressed state of the struts. This line is 12.90m long giving a dish diameter of 4.1m and the preloading of the struts because they cannot relax into their straight shape, even if the guywires are removed [25].

The feed pole is a standard aluminium tube 1950mm x 30mm x 3mm, extended at the feed end by a glassfibre reinforced polyester tube of 1000mm x 40mm x 4mm. The glass fibre portion must not be shorter than this because a metal structure close to the mouth of the waveguide feeder would severely interfere with

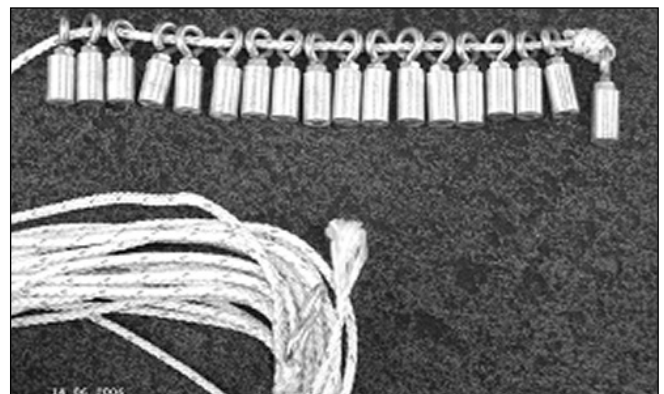

**Fig 17.48: Front guy wires for preloaded stressed dish**



**Fig 17.49: Square waveguide feeder built by Zdenek Samek, OK1DFC, fitted to the pre-loaded stressed dish**



**Fig 17.50: 70cm feed from Luis Cupido, CT1DMK, fitted to the pre-loaded stressed dish**

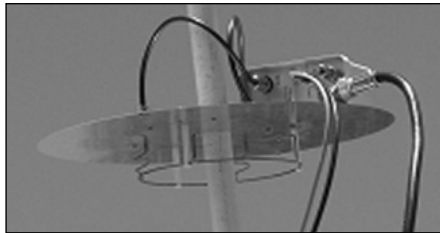

the electromagnetic field illuminating the dish, resulting in loss of proper circular polarisation (CP). The mesh segments are all identical, made from aluminium wire mesh 5mm x 5mm x 0.7mm (galvanized chicken wire is also suitable, but at the expense of additional weight). They are pre-cut from a roll in a trapezoidal shape (1800mm long, 180mm small end, 760mm large end) ensuring an overlap of 40mm when the segments are mounted. The mesh panels are tied to the struts by flower binding wire, this is effective, reusable and cheap.

With this dish, any waveguide type of feeder may be used for 23cm and above; however, the easiest way of mounting a proper CP feed to the support pole is by attaching the original OK1DFC square WG feeder by a set of aluminium clamps, as can be seen in **Fig 17.49**. When stressing the dish to 0.45 f/D or deeper, no flare or choke ring is required on the feed for optimum illumination.

This stressed dish was also used on 70cm with convincing receive capabilities because a dish picks up less ground noise than a comparable yagi array of approximately 21dBd gain. The 70cm feed used was a modified version of the 1 wavelength loop feed described by CT1DMK [26]. The feed line length was changed from the originally quarter-wave to three-quarter-wave because the relays used for H/V polarization switching were shorted to ground on NO (the common CX-520D relay), the reflector has a five-eighths-wavelength diameter, which is a trade-off for minimised dish blockage and 3dB radiation angle of the feed, see **Fig 17.50**.

## REFERENCES

- [1] 'Practical project: A patch antenna for 5.8GHz', Gunthard Kraus, DG8GB, *VHF Communications Magazine* 1/2004, pp 20 - 29
- [2] 'Modern patch antenna design', Part 1, G Kraus, DG8GB, *VHF Communications Magazine* 1/2001, pp 49 - 63
- [3] 'Modern patch antenna design', Part 2, G Kraus, DG8GB, *VHF Communications Magazine* 2/2001, pp. 66 - 86
- [4] Search for *patch16.zip*, by WB0DGF, on the Internet. One source is: <http://www.nic.funet.fi/pub/ham/antenna/>
- [5] 'PUFF - a CAD program for microwave stripline circuits', Robert E Lentz, DL3WR, *VHF Communications Magazine* 2/1991, pp 66 - 69. 'PUFF 2.1 - improved and expanded version', Dipl Ing A Gerstlauer, DG5SEB, *VHF Communications Magazine* 2/1998, pp 97 - 101
- [6] 'An interesting program MSTRIP', G Kraus, DG8GB, *VHF Communications Magazine* 2/2002, pp 69 - 85
- [7] 'An interesting program. SonnetLite 9.51', G Kraus, DG8GB, *VHF Communications Magazine* 3/2004, pp 156 - 178
- [8] 'An array of 4x16 turn helix antennas for 2402MHz', P Pitacco, IW3QBN, *VHF Communications Magazine* 1/2004, pp 2 - 6
- [9] 'Antenne a elica, esperienze utili per tutti', Paolo Pitacco, IW3QBN, *AMSAT-I News* Vol8, N3, p13
- [10] 'Un'elica di 16 spire per la banda S', G3RUH (translated IOQIT), *AMSAT-I News* Vol5, N1, p19
- [11] 'HELIX.BAS Basic program for Helix design', KA1GT, *UHF/Microwave Experimenters Manual* (ARRL), pp 9-49
- [12] *Antennas*, J D Kraus, R J Marhefka, McGraw Hill - 3th ed.
- [13] *Antenna Engineering Handbook*, McGraw-Hill Book Company.
- [14] Contribution by Noel Hunkeler, F5JJO, to 'Technical topics', *RadCom* July 1997, p 72
- [15] From an article by Leo Lorentzen, OZ3TZ, *OZ* 1/2001, pp 18 -20 and *OZ* 11/2000, pp. 633 - 635
- [16] *Paul Wade Antenna Book*, chapter 5; 'Offset-Fed Parabolic Dish Antennas', [www.w1ghz.org/antbook/chap5.pdf](http://www.w1ghz.org/antbook/chap5.pdf)
- [17] Z Lau, KH6CP/1, 'RF', *QEX*, March 1995, p24
- [18] 'Calculating the Focal Point of an Offset Antenna', Ing. Jiri Otypka, CSc, *VHF Communications Magazine*, 1/1995, pp 25 - 30, [www.vhfcomm.co.uk/pdf/Offset Dish 1-95.pdf](http://www.vhfcomm.co.uk/pdf/Offset%20Dish%201-95.pdf)
- [19] *HDL\_ANT* ver 3b4: [www.w1ghz.org/software/hdl\\_3b4\\_all.zip](http://www.w1ghz.org/software/hdl_3b4_all.zip)
- [20] D Evans, G3RPE, 'Pyramidal horn feeds for paraboloidal dishes', *RadCom*, March 1975
- [21] V Jamnejad-Dailami and Y Rahmat-Samii, 'Some Important Geometric Features of Conic-Section-Generated Offset Reflector Antennas', *IEEE Transactions on Antennas and Propagation*, AP-28, Nov 1980, pp 952 - 957
- [22] R T Knadle, K2RIW, 'A Twelve-Foot Stressed Parabolic Dish', *QST*, Aug. 1972
- [23] Z Samek, OK1DFC, paper in *Proc 10th EME-Conference in Prague, 2002*; [www.ok1dfc.com/eme/emeweb.htm](http://www.ok1dfc.com/eme/emeweb.htm)
- [24] Dr M Kohla, DL1YMK, paper in *Proc 12th EME-Conference in Würzburg, 2006*; [www.ok1dfc.com/peditions/El-DL1YMK/index.html](http://www.ok1dfc.com/peditions/El-DL1YMK/index.html)
- [25] <http://www.skatelescope.org/publications/>
- [26] L Cupido, CT1DMK, '70cm Deep Dish Loop Feed', *Dubus* 3/2002

## About the Author

**Andy Barter** was an apprentice at ICL in the 1960s where he trained as an electronics engineer. He spent 15 years working in the electronics industry before becoming a computer consultant for a further 20 years. He is now self-employed, publishing the popular VHF Communications magazine and carrying out consultancy work. Andy is also the editor of The International Microwave Handbook, VHF/UHF Handbook, Microwave Projects and Microwave Projects 2.

He was licensed as G8ATD in 1966 and has for many years spent his time constructing UHF and microwave equipment for use in contests. Andy lives in Luton, Bedfordshire, UK and is an active member of the Shefford & District Amateur Radio Society, where he is the contest organiser, and The Luton VHF Group, G3SVJ who take part in VHF, UHF and Microwave contests.